

## Flow-Through Centerpiece Assembly For Use in ProteomeLab™ XL-A and XL-I Instruments

### Description

The flow-through centerpiece assembly is shown in Figure 1; components of the assembly are shown in Figure 2. The flow-through centerpiece has two filling holes per sector, as opposed to the standard centerpiece with only one hole per sector. The extra filling hole enables the centerpiece to be cleaned by flushing cleaning solution into and out of each centerpiece sector.

To keep the new centerpiece clean, the assembly ships with brass housing plugs and red plug gaskets over the filling holes. Before the first use of the assembly, remove the plugs with screwdriver (807371), found in toolkit (362106), and carefully remove the gaskets using small tweezers. Discard the gaskets and install new ones before each use of the centerpiece to ensure that the filling holes are properly sealed. After each use, clean the assembly following the procedure below.

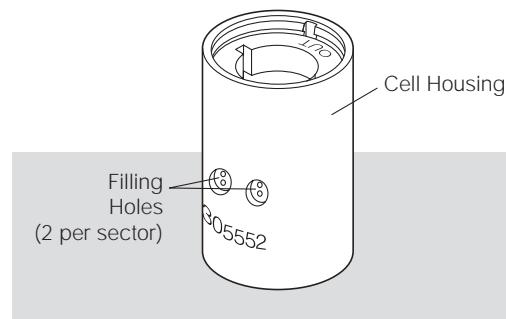

*Figure 1. The Flow-Through Centerpiece Assembly*

### Assembly Components

Flow-through 12-mm centerpiece assembly with quartz windows . . . . . 392772  
 Flow-through 12-mm centerpiece assembly with sapphire windows . . . . . 392773

In addition to the quartz windows (301730, qty/2) in assembly 392772 and the sapphire windows (307177, qty/2) in assembly 392773, the assemblies contain the following common components:

Description	Assembly Quantity	Reorder Part Number	Reorder Quantity	Description	Assembly Quantity	Reorder Part Number	Reorder Quantity
Cell housing, two-sector, aluminum	1	305552	1	Screw ring washer, Bakelite	1	362328	6
Centerpiece, two-sector 12-mm flow-through, Epon	1	392778	1	Window gasket, white vinylite	2	327021	100
Plug gasket, red polyethylene	2	327022	100	Window holder, aluminum	2	305037	1
Housing plug, brass	2	362327	6	Window liner, Bakelite	2	362329	6
Screw ring, aluminum	1	301922	1				

## Accessory Kit

Accessory kit 392777 contains the following spare parts and supplies for use with the flow-through centerpiece assemblies.

Plug, brass (qty/6) . . . . .	362327
Plug gasket, red polyethylene (qty/100) . . . . .	327022
Window gasket, white vinylite (qty/100) . . . . .	327021
Cell alignment tool (qty/1) . . . . .	362340
Spinkote lubricant (2 oz). . . . .	306812

## Required Items

The following items are required for the cleaning procedure, but not supplied.

- 10-mL syringe (1)
- Tubing (Hamilton Teflon #90630 or equivalent is recommended. See the Hamilton website [www.hamiltoncompany.com/product/oem/oem-teflon.html](http://www.hamiltoncompany.com/product/oem/oem-teflon.html) for more information.)
- Pipette (Gilson P-200 or equivalent) with gel-loading tip (1)

## Cleaning Procedure

Perform this procedure over a sink or tray to collect the cleaning and rinsing agents that exit the centerpiece.

1. Fill the syringe with 5 mL of 10% SDS.
2. Connect the tubing hub end to the 10-mL syringe, and the other tubing end to a filling hole in the centerpiece assembly (see Figure 3). For each sector, either filling hole can be used.
3. Inject the syringe contents into the centerpiece.
4. Refill the syringe with 10 mL of deionized water and inject it. Repeat with another 10 mL of deionized water. (Use the same tubing that was used in step 2. It is necessary to flush the SDS out of the tubing to prevent clogging and to ensure that the tubing can be re-used.)

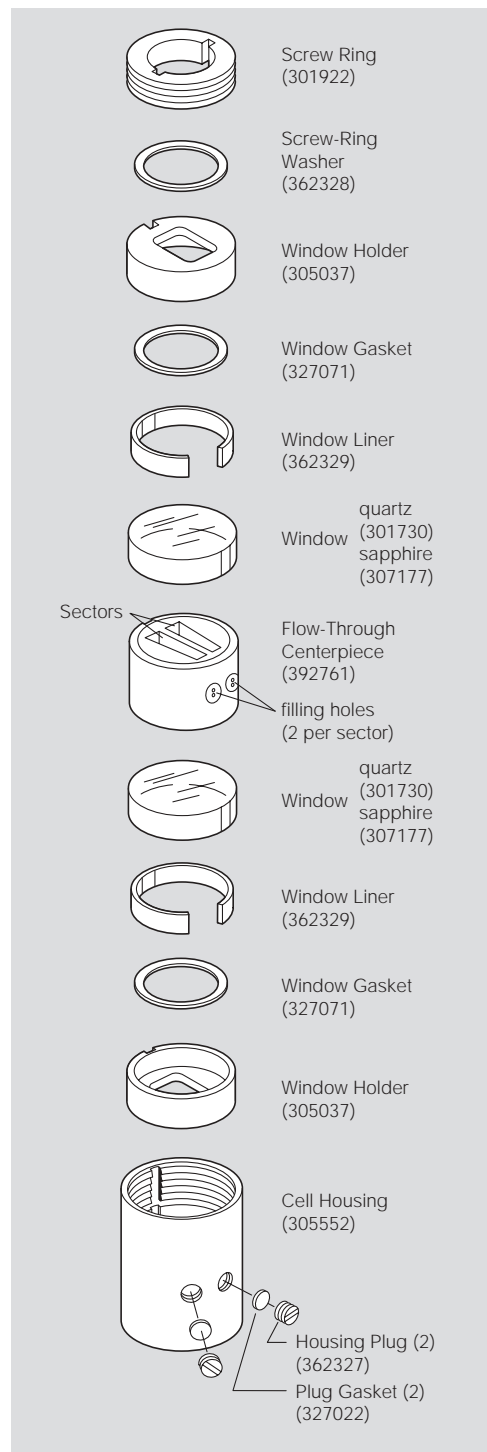

Figure 2. Components of the Flow-Through Centerpiece Assembly

5. Remove as much as possible of the residual liquid from the centerpiece using a pipette and gel-loading tips (see Figure 4).
6. Dry the centerpiece thoroughly using any of the methods below. We recommend using step b followed by step c.
  - a. Air-dry the centerpiece. It will take several hours to dry completely.
  - b. Inject 3 mL of 70% ethanol into the centerpiece. Remove residual ethanol from the centerpiece with a pipette and gel-loading tip.
  - c. Place the centerpiece assembly in a dessicator, connecting to vacuum, and run for 10 to 15 minutes or until dry.

If you use step b followed by step c, the centerpiece assembly will be ready for re-use immediately.

**NOTE**

If you suspect that protein is sticking in the cell after thorough cleaning, inject approximately 0.5 mL of 1 millimolar HCl (enough to fill the sectors) into the centerpiece and soak the cell for a minimum of 2 hours, preferably overnight. Optionally you can add 1 mg/mL pepsin to the HCl. Repeat cleaning steps 1 through 5 again after the soak is complete.

Alternately, disassemble the cell and soak the centerpiece and windows in HCl (1 mM) and pepsin (1 mg/mL) for 2 hours to overnight. Clean all parts and reassemble the cell. (The analytical rotor manual contains cell disassembly, cleaning, and reassembly instructions.)

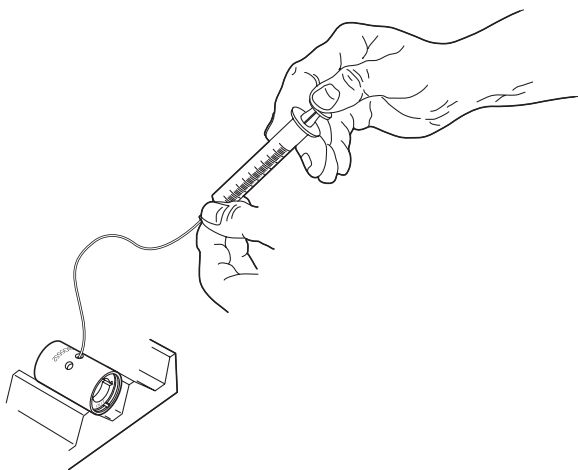

Figure 3. Connect Tubing and Syringe to the Centerpiece

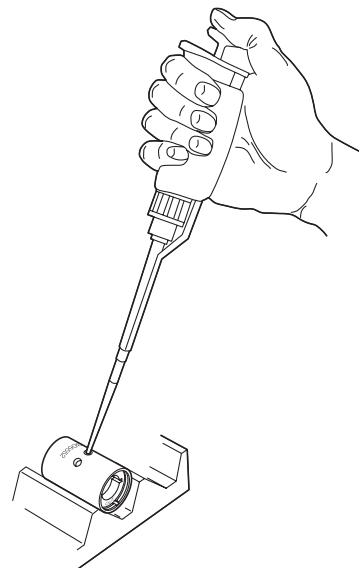

Figure 4. Remove Residual Liquid from the Centerpiece Using a Pipette

7. **Important:** before re-use, place the centerpiece assembly in the cell torque stand and use the cell torque wrench to ensure that the screw ring is tightened to 120 inch-pounds (see Figure 5). Refer to litpak 363548, *How to Use the Analytical Torque Stand and Torque Wrench*, for complete instructions on torquing the cell.

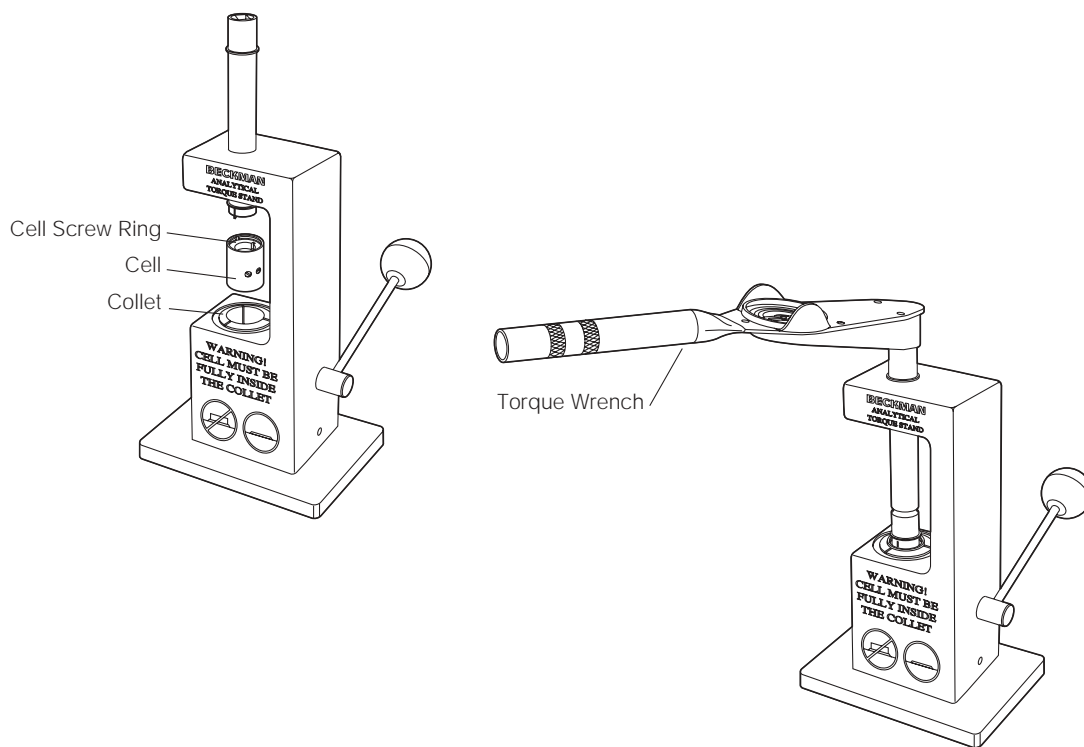

Figure 5. Insert Cell Into the Torque Stand Collet and Check Screw Ring Tightness

## Dissassembling the Centerpiece

The centerpiece requires periodic disassembly, cleaning, and reassembly to ensure that it is thoroughly clean. Refer to publication LXL/A-TB-003 for detailed instructions on the use and care of the analytical rotor.

### NOTE

To receive copies of referenced publications, contact Beckman Coulter, Inc., Technical publications Department, 1050 Page Mill Road, Palo Alto, CA 94304, U.S.A. (Telephone 650-859-1753; Fax 650-859-1375).

Beckman Coulter, Inc. • 4300 N. Harbor Boulevard, Box 3100 • Fullerton, California 92834-3100  
Sales: 1-800-742-2345 • Service: 1-800-551-1150 • Internet: [www.beckmancoulter.com](http://www.beckmancoulter.com) • Telex: 678413 • Fax: 1-800-643-4366

